



PROMETH₂O

20IND06 PROMETH2O

Metrology for trace water in ultra-pure process gases

Training course

Morning - Golf Club Settimo, strada Cebrosa 166 Settimo Torinese (TO) - Italy

Afternoon - Nippon Gases, via Marie Curie 134/D Chivasso (TO) - Italy

Thursday 7th of March 2024

EMPIR



EURAMET

The EMPIR initiative is co-funded by the European Union's Horizon 2020 research and innovation programme and the EMPIR Participating States

Trace water measurements: practical considerations

Domen Hudoklin

Outline

- measuring at high humidity – sampling issues
 - measuring at trace water levels – connections, leakages
-

Issues

- unwanted condensation - common cause of error in hygrometry
 - cold spots – temperature below dew point $t < t_{\text{dew}}$
 - invalid sampling – change in the water vapor content
 - can remain undetected
-

- Condensation dew-point meters are of the highest quality reference instruments
- Problems when measuring dew-point temperatures which are higher than outside temperature

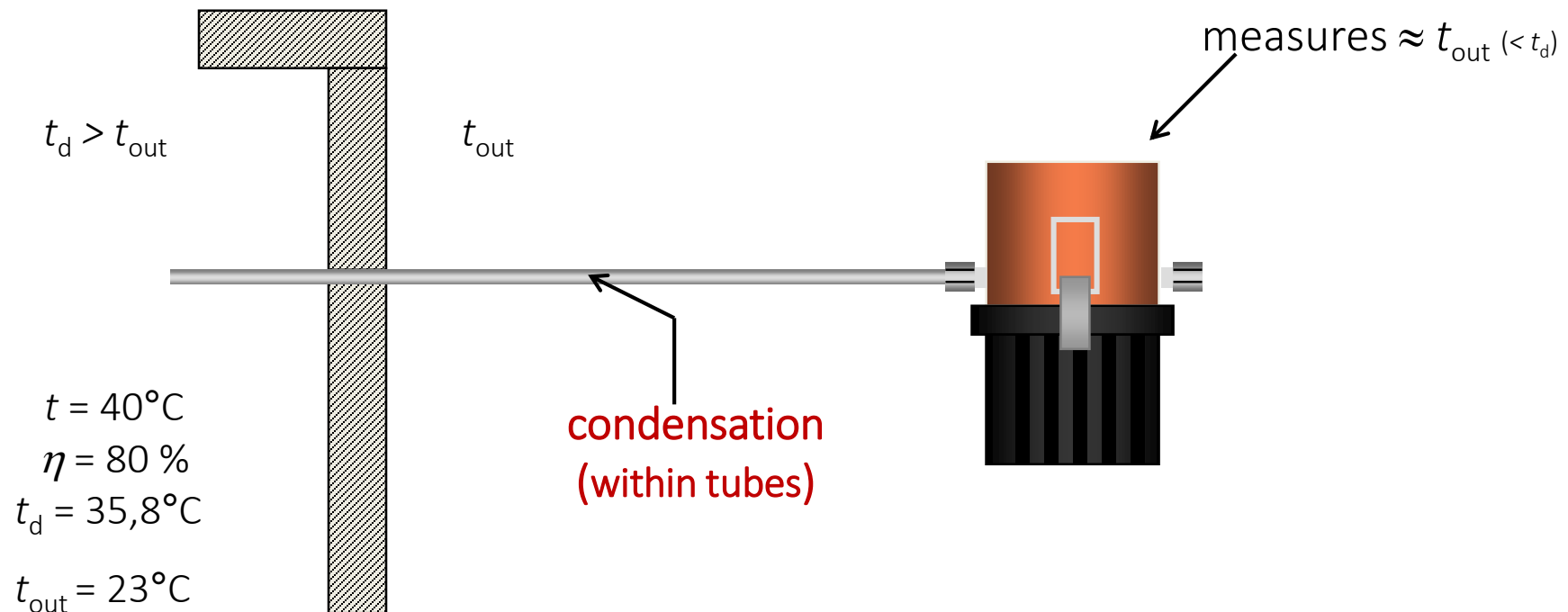

- Condensation dew-point meters are of the highest quality reference instruments
- Problems when measuring dew-point temperatures which are higher than outside temperature

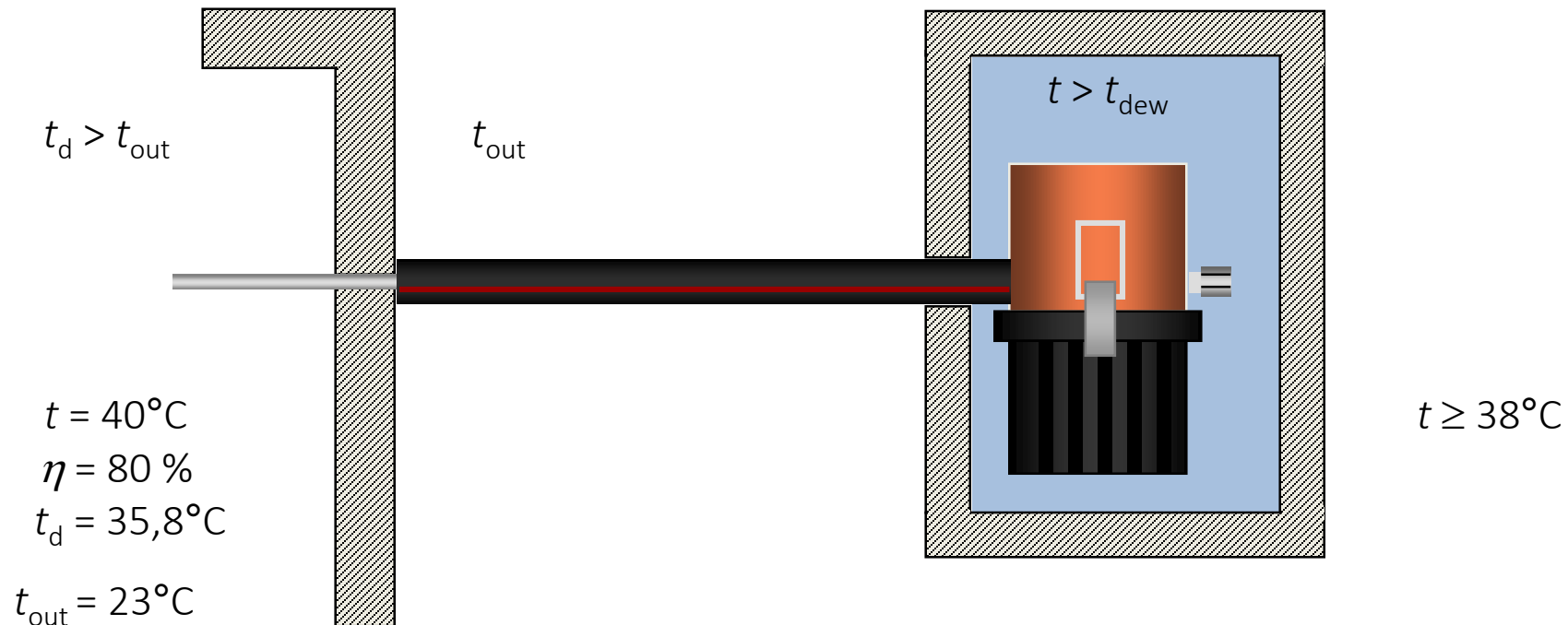

- condensation dew-point meters are highest quality reference instruments
- problems when measuring dew-point temperatures which are higher than outside temperature

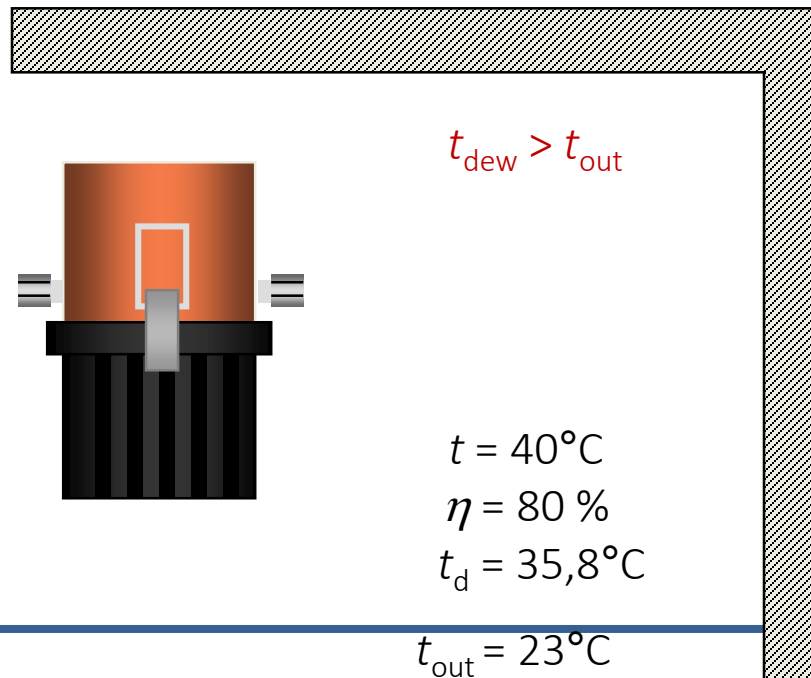

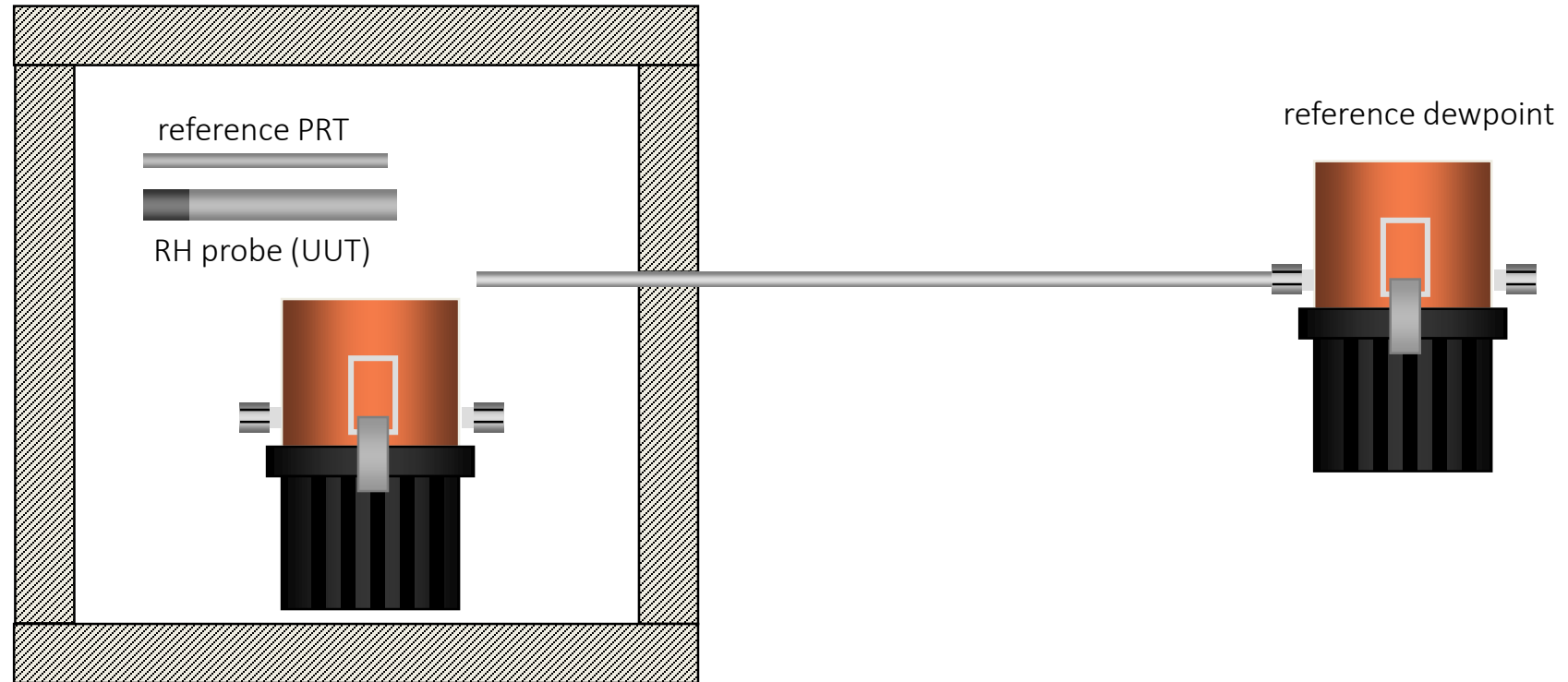

Impedance based hygrometers

- leakage and heat transfer along the sensor body

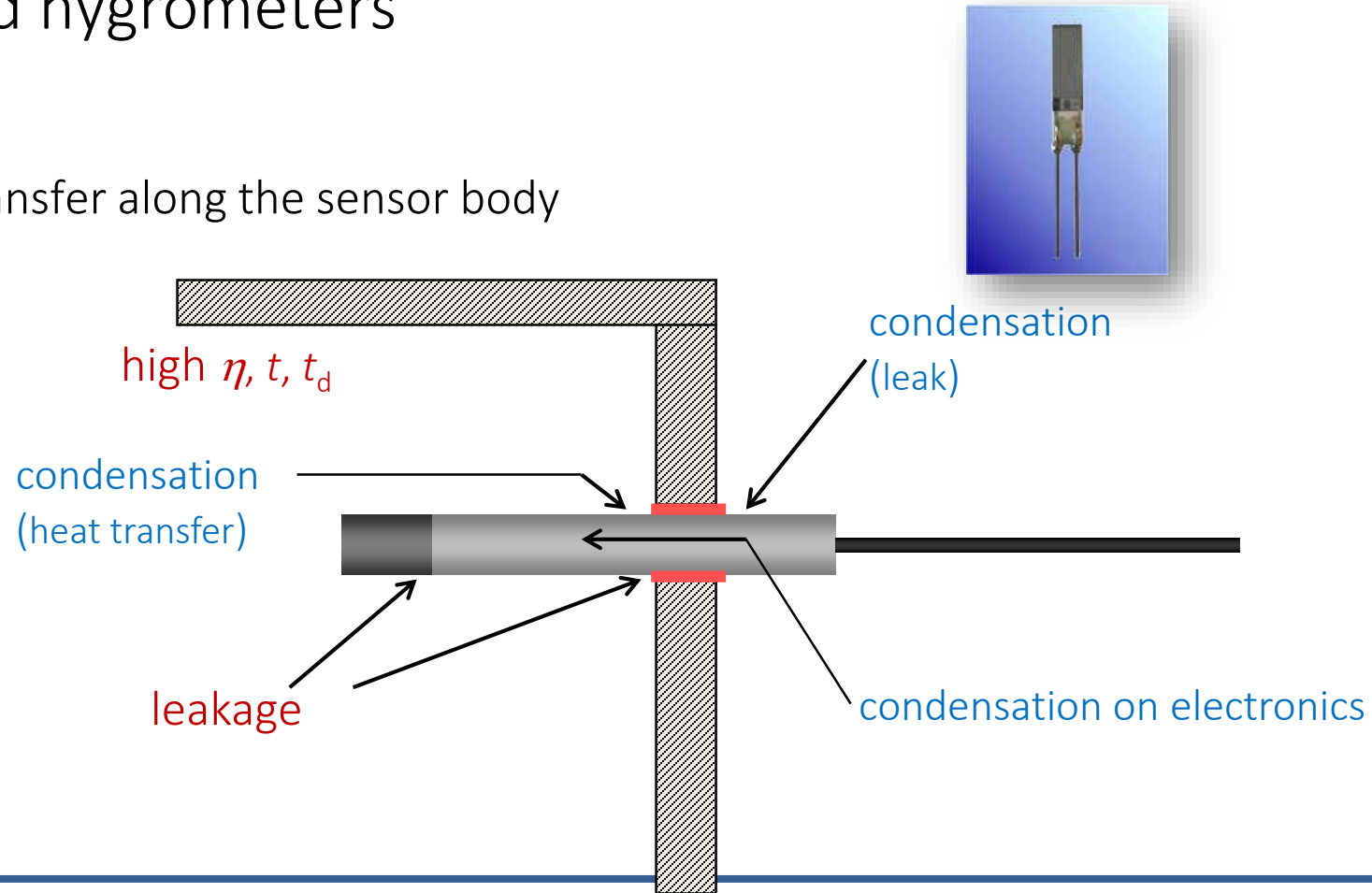

- influence of temperature on measured RH:
 - difference of few %rh
 - calibrate at temperature that you are using
- dew point temperature is calculated and not actually measured
- non-linearity and hysteresis are part of uncertainty
- some of the instruments **@ freezing t** , error up to 2% (standard vs. WMO definition of relative humidity)



Other issues

- leaks
 - gasket installation (O-ring compression, groove dimension, PTFE thread tape,...)
 - scratches
 - gasket material – permeation (EPDM, FKM, PTFE, metal,...)
 - virtual leaks
 - adsorption, desorption
 - stabilization time – hours, days
 - contamination (affecting partial pressure, leakage, sensor response)
-

- Leakages
 - gasket installation (O-ring compression, groove dimension, PTFE thread tape,...)
 - scratches
 - gasket material – permeation (EPDM, FKM, PTFE, metal,...)
 - virtual leaks



Permeation Coefficients (10⁻⁸ sccm - cm/sec - cm² - atm)

MATERIAL	HE	H2	H2O	N2	CO2
Buna-N	8	2.5	760	0.1	25
EPDM	25-30	16-18		6-7	85
Silicone	250	75-450	8,000	200	2,000
Fluorosilicone	140	80		40	400
FKM Viton ® A	9-22	1-2	40	0.05-0.7	5
FKM Viton ® GF	30	3		2	
Markez ® FFKM	60-80	6-8	90-100	8-12	
KEL-F		0.1		0.1	0.5
PTFE		0.4		0.14	0.12
Polyimide	1.9	0.1		0.3	0.2

Source: <https://www.marcorubber.com/o-ring-permeation.htm>

plastic



very limited use /
unsuitable



scratches



swaged fitting



imperial / metric

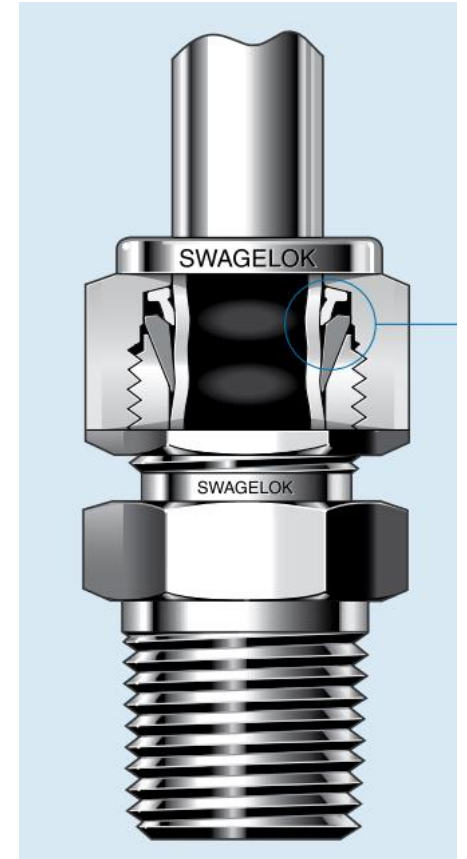

ball valves



- reusable
- low leakage
- with(out) welding

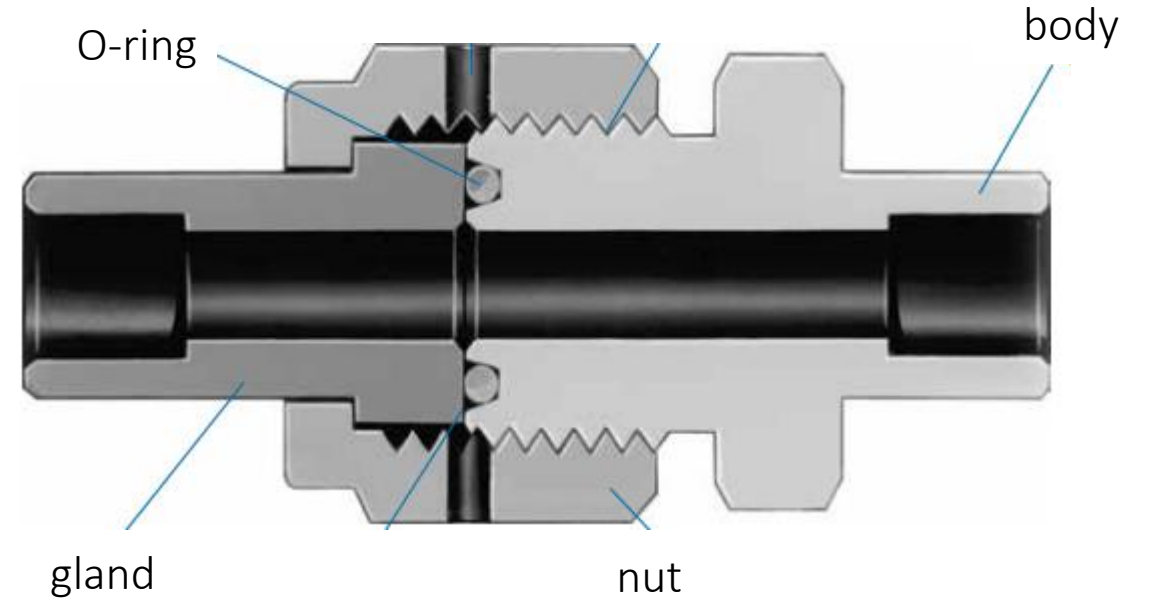

O-ring



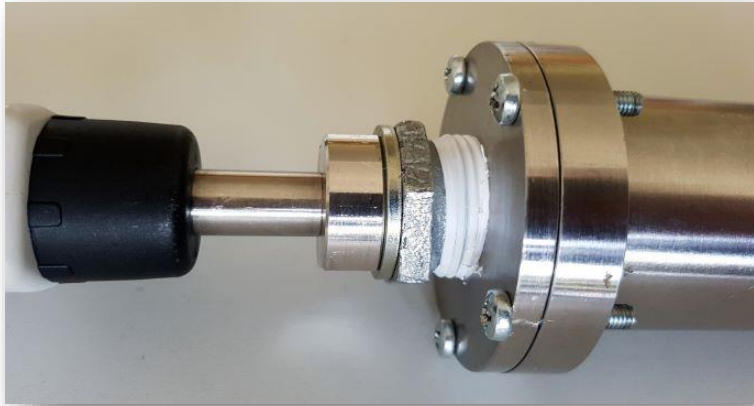

- teflon tape
 - tight if carefully wound onto a thread (no. of turns, winding direction, finishing,...)
 - used for cryo applications
-

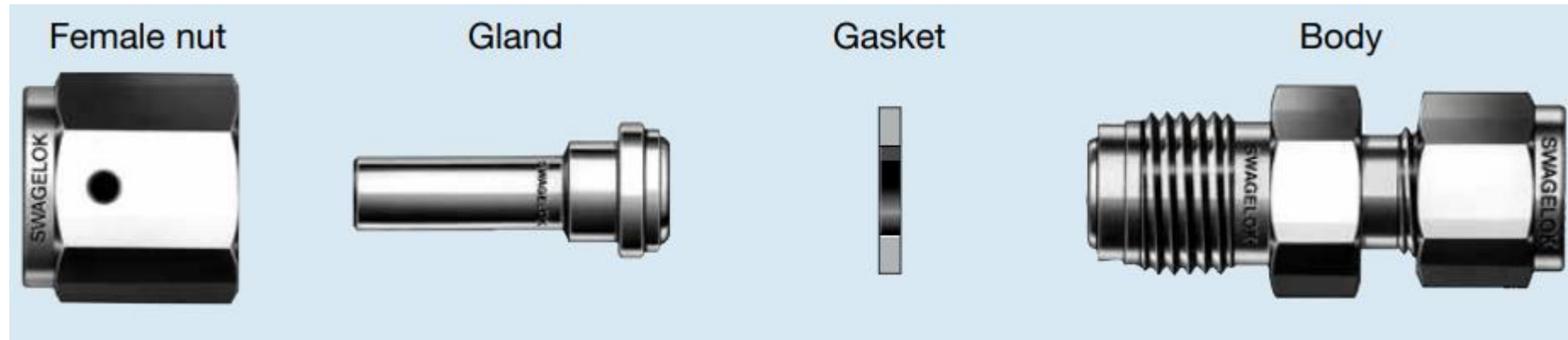

- leak tight ($< 10^{-10}$ mbar·l/s)
- metal gasket replacement each time
- requires welding for max. tightness

ultra high purity with metal gasket

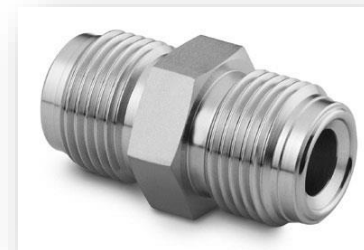

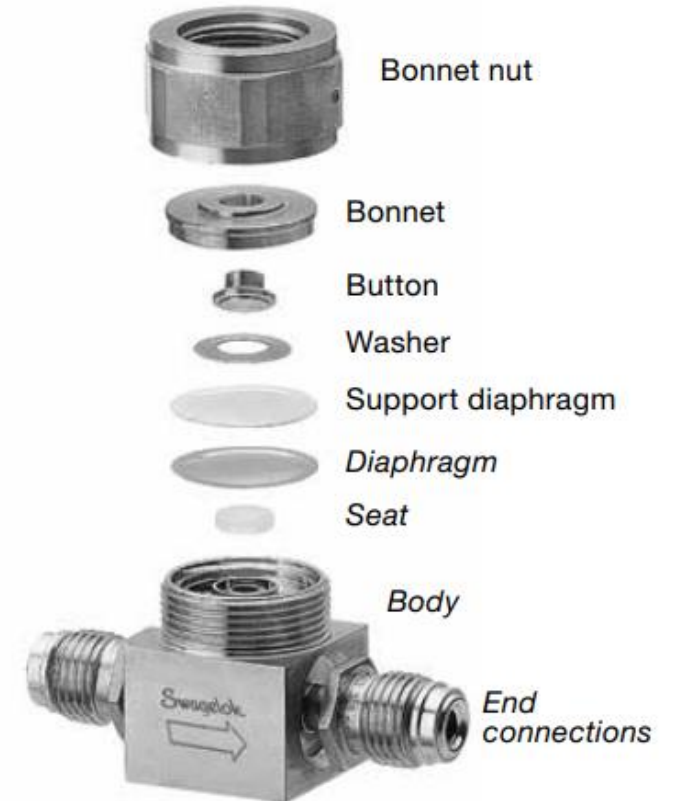

unsuitable or only around room
humidity

PVC



Vinyl



stainless steel tubes,
surface polish (Ra below 0,13 µm)



PTFE (teflon) – high to mid range



unsuitable or only around room
humidity



CVD (chemical vapour deposition) coating –
made of amorphous silicon (a-Si)



SilcoNert-coated Sampling Parts

stainless steel tubes,
surface polish (Ra below 0,13 µm)



PTFE (teflon) – high to mid range

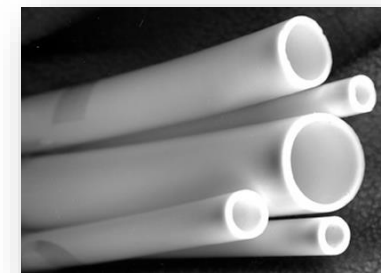

unsuitable or only around room
humidity

PVC



Vinyl



stainless steel tubes,
surface polish (Ra below 0,13 µm)



heated tube



flexible
metal
tubes



Thank you for your attention!

